

Non-uniform imaging

SINA 2010/11

Non-uniform sensors

...vision is an information processing task...

One of the major concerns of evolution has been to shape the sensory systems so that information is reduced as soon as possible (ideally even before it enters the processing device)

...may be less information is better

One example is the structure of the human retina

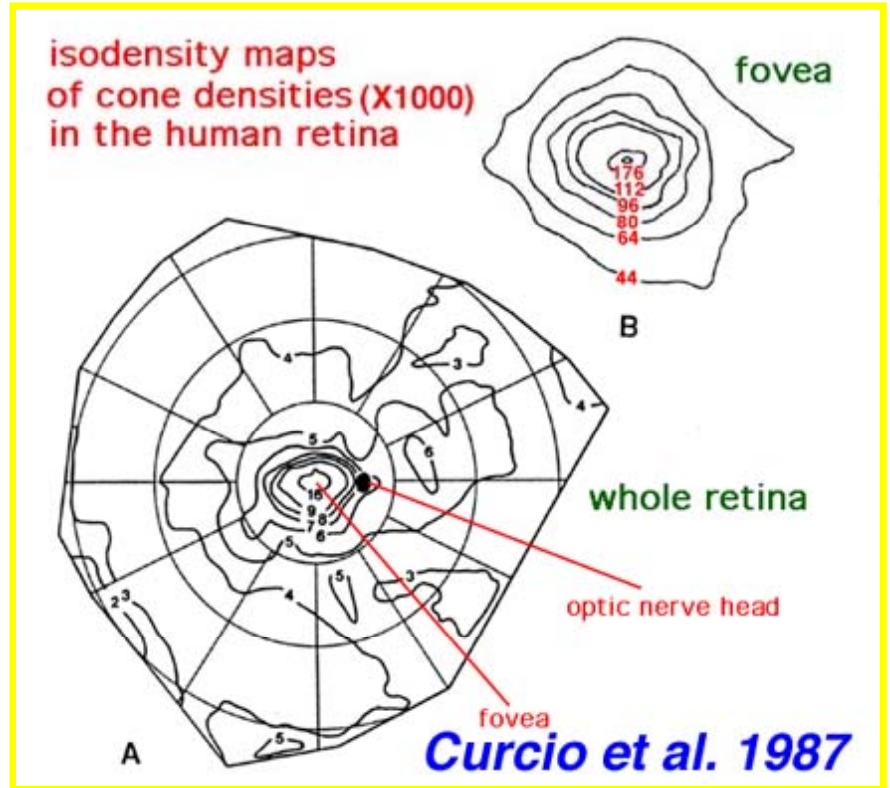
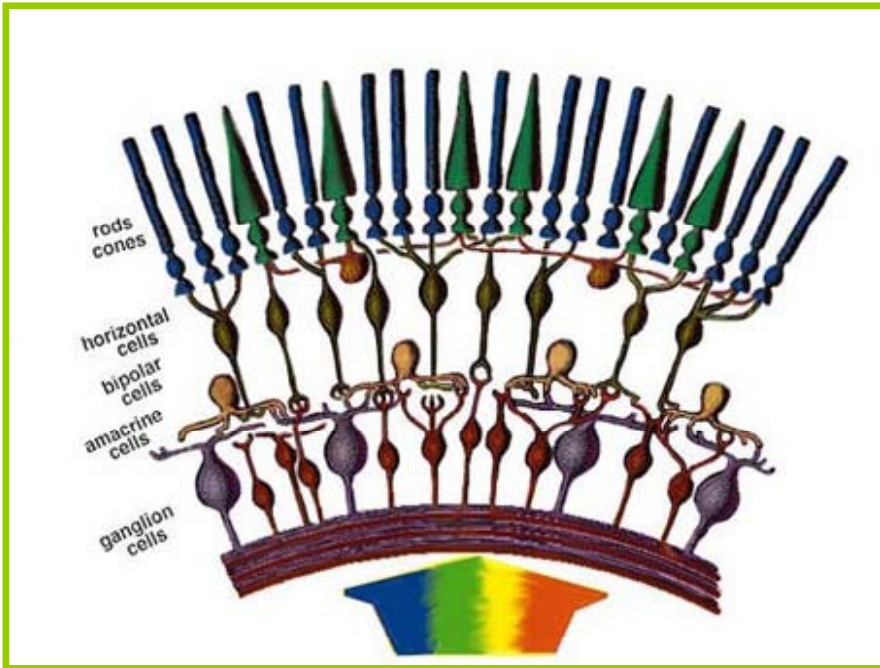

Distribution of the receptors

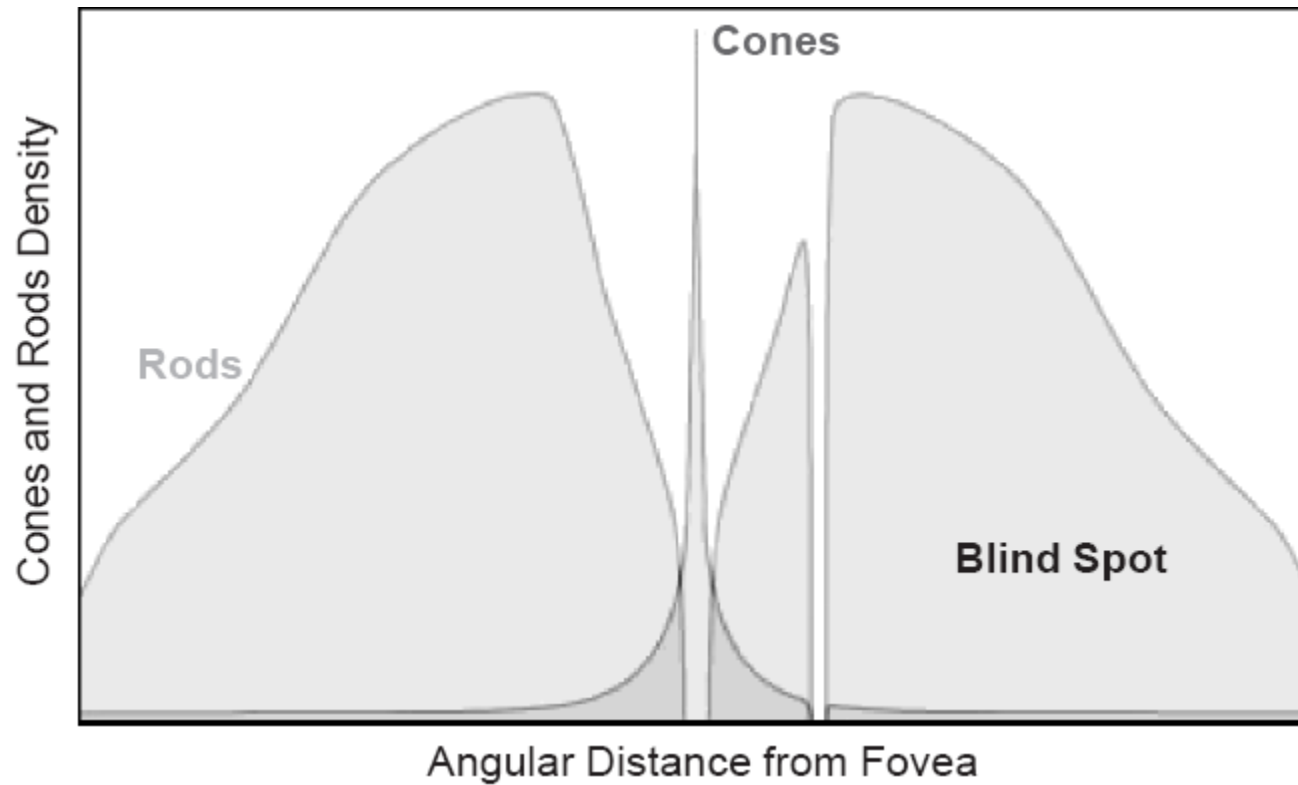

If the retina was designed as a camera

Visual Field: about 160 deg

Maximum Resolution: about 1/60 deg

According to K. Nakayama and E. Schwartz the saving is from 5,000 to 30,000 times.

Optic nerve: diameter 4 cm

Brain weight: from about 3 to 20 tons

Amount of food: ?

Processing time: ?

The mammalian eye is a remarkable optical device, but its design is not perfect. The blood vessels that supply the inner retina are located in front of the photoreceptor layer, blocking access to light. Their shadows create a pattern of blindness in the field of vision that corresponds precisely to the location of the largest vessels in the eye. We show here that in squirrel monkeys, focal deprivation by blood vessels leads to rewiring of the eye's geniculocortical projections, imprinting an image of the retinal vascular tree onto the primary visual cortex. This process illustrates vividly that local imbalances in neuronal activity can influence column formation during normal development.

Shadows Cast by Retinal Blood Vessels Mapped in Primary Visual Cortex

Daniel L. Adams and Jonathan C. Horton

SCIENCE VOL 298 18 OCTOBER 2002

Ocular dominance columns

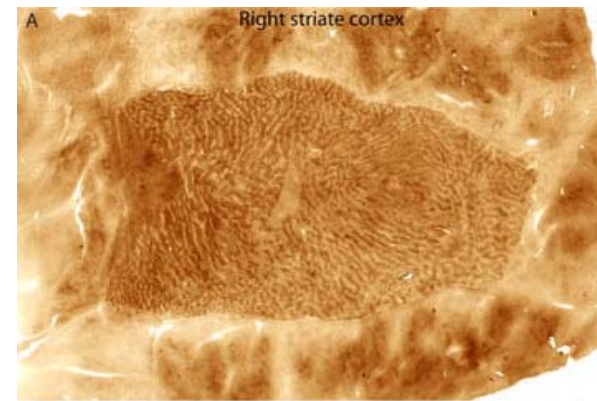
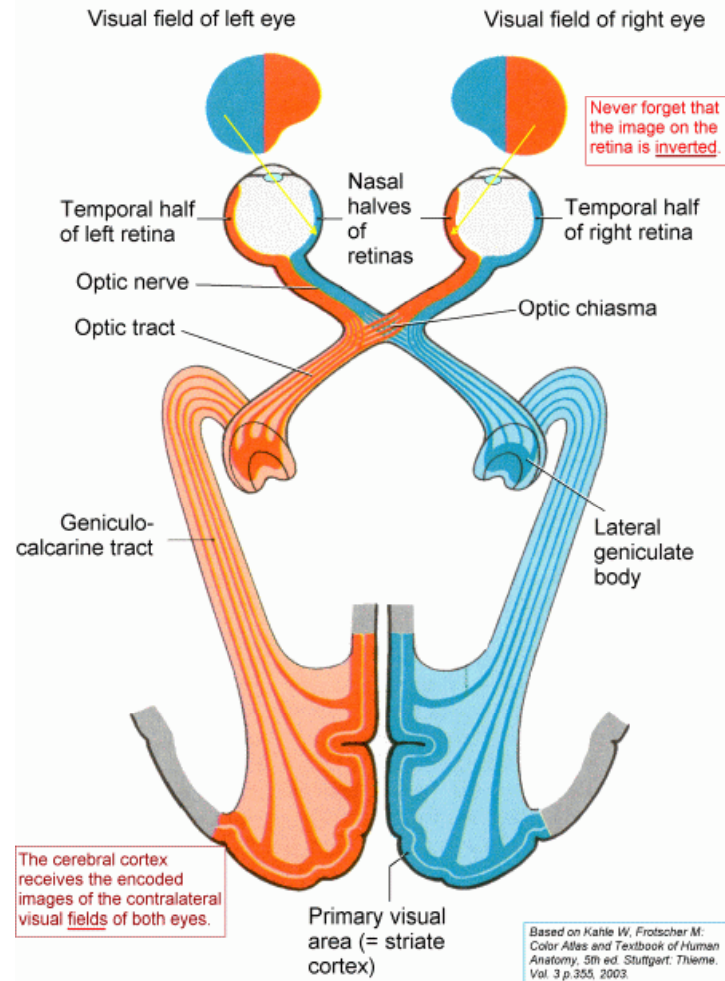

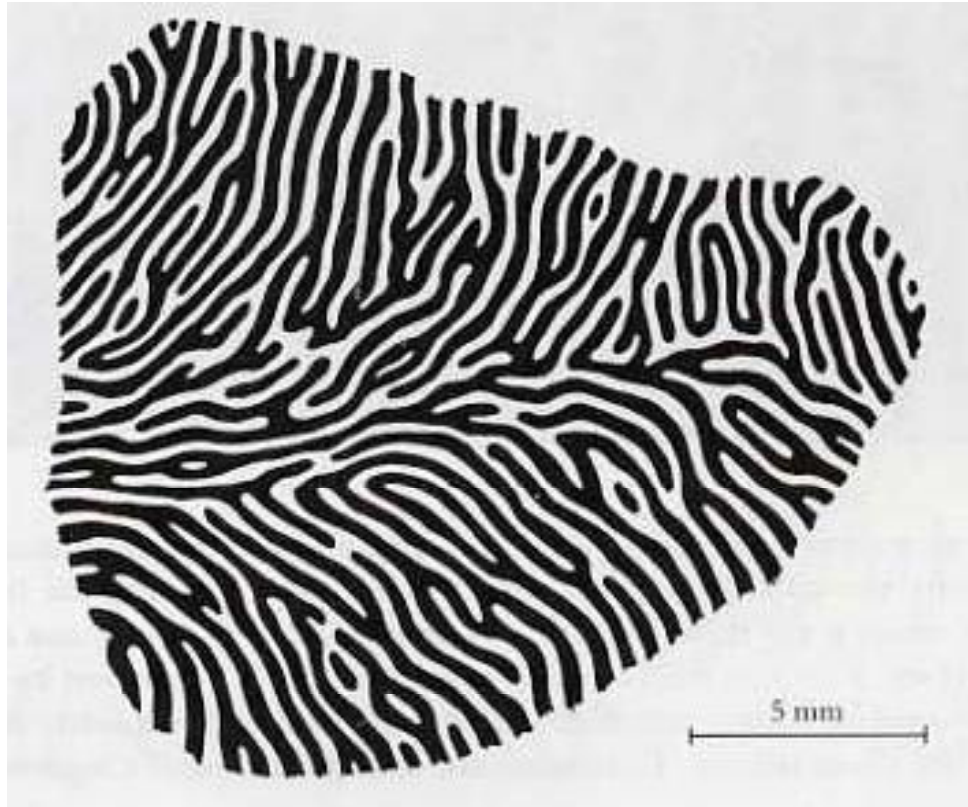

From macaque data

Schematics (after development)

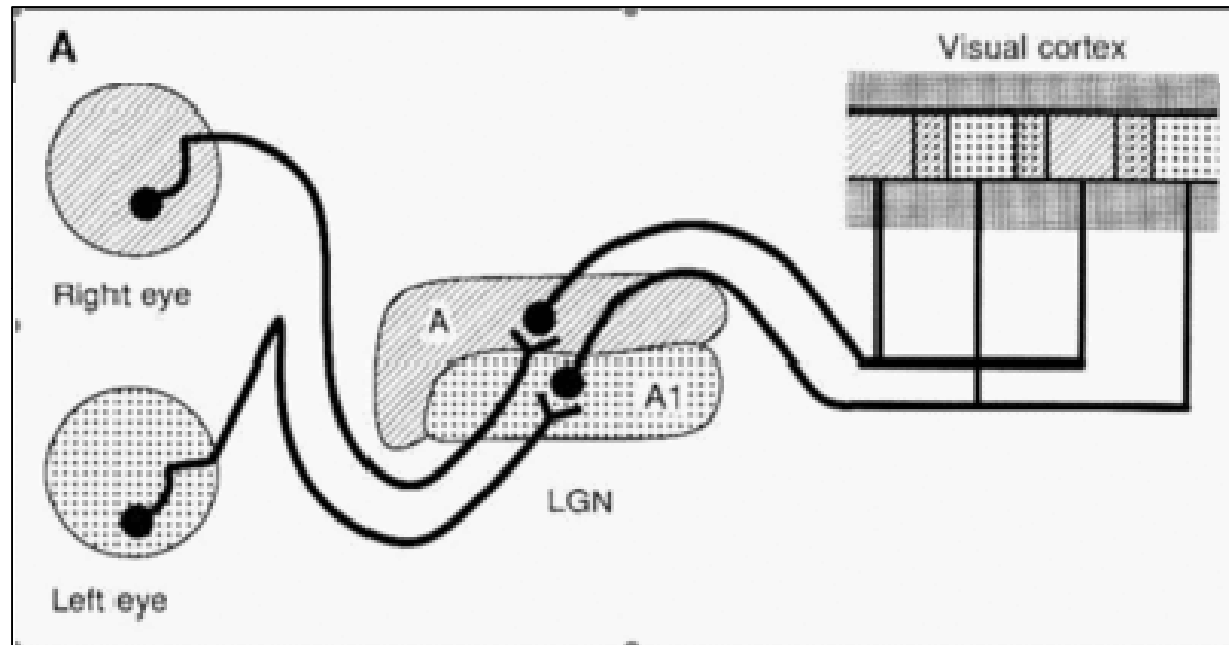

A growing body of experimental data supports the notion that both patterned spontaneous retinal activity and axon guidance cues together contribute to the formation of ocular dominance columns. Once the initial circuit is formed, studies demonstrate a critical period of time during which ocular dominance columns can be modified in response to visual experience.

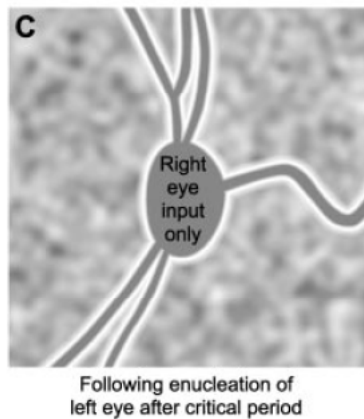
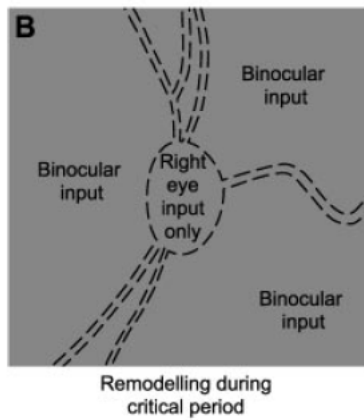
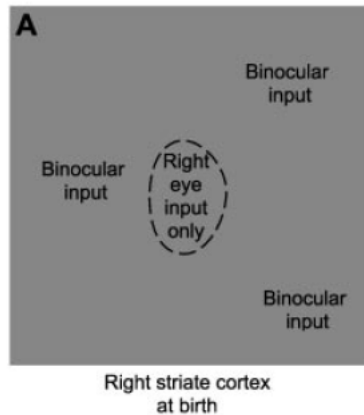

Fig. 2. CO (cytochrome oxidase) staining of angioscotoma representations.

(A) At birth, CO staining is uniform.

Angioscotomas are absent, but the right eye already monopolizes the left eye's blind spot representation.

(B) After light exposure, vessels begin to cast shadows, generating angioscotoma representations. Their pattern becomes immutable at the end of the critical period.

(C) Removal of one eye induces an undulating pattern of CO activity, corresponding to the ocular dominance columns. The angioscotomas appear silhouetted against this textured background, because they stain solidly. Note the tendency for the other eye to "frost" the vessel and blind spot representations.

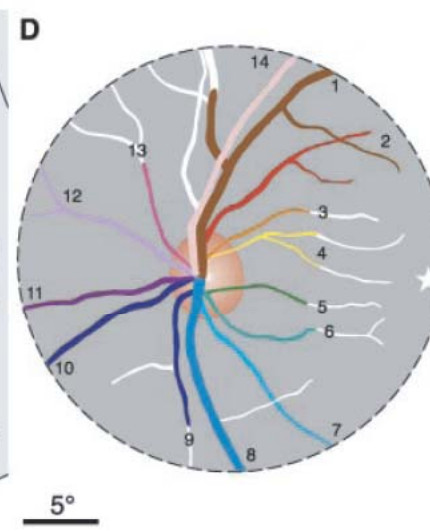
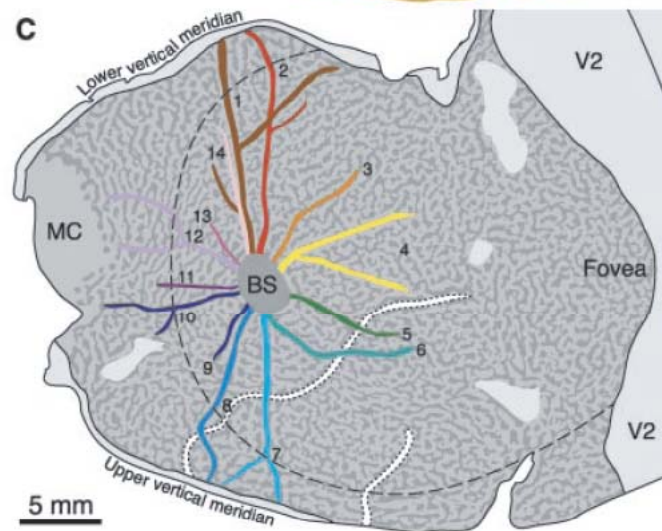
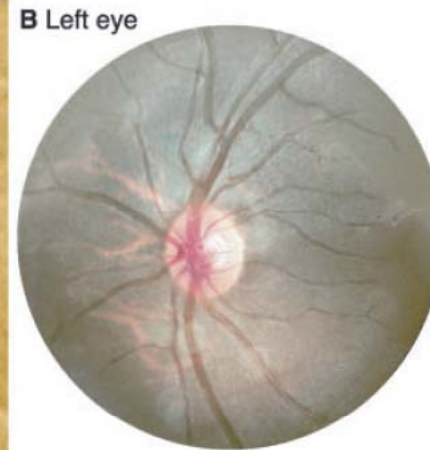
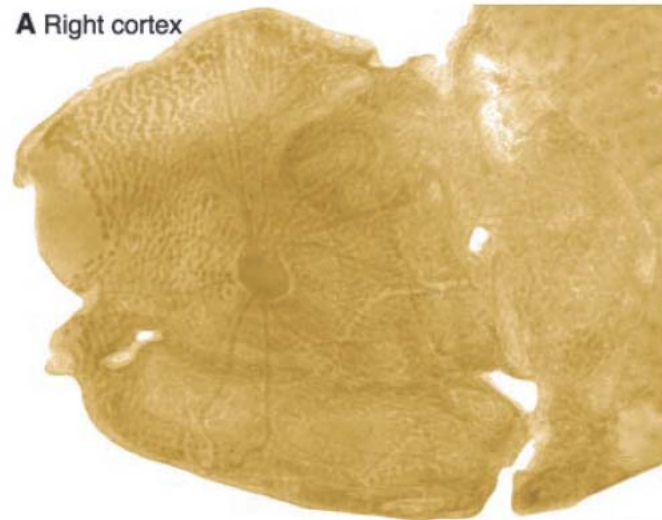

V1 (primary visual cortex)

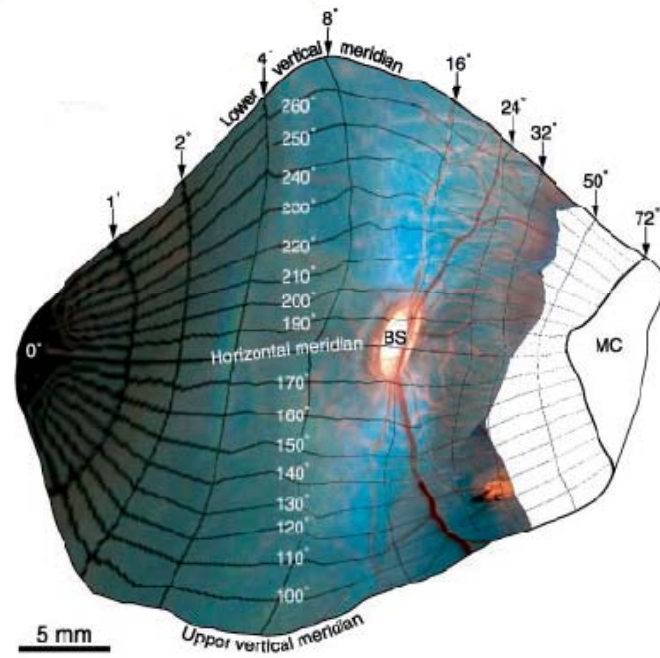
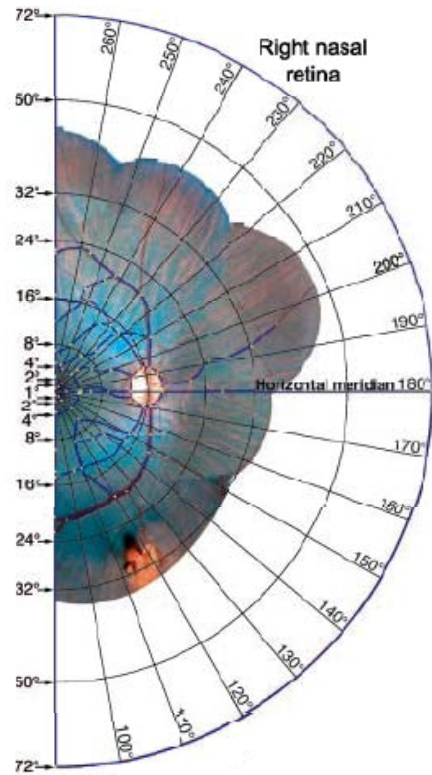

Cortical magnification factor

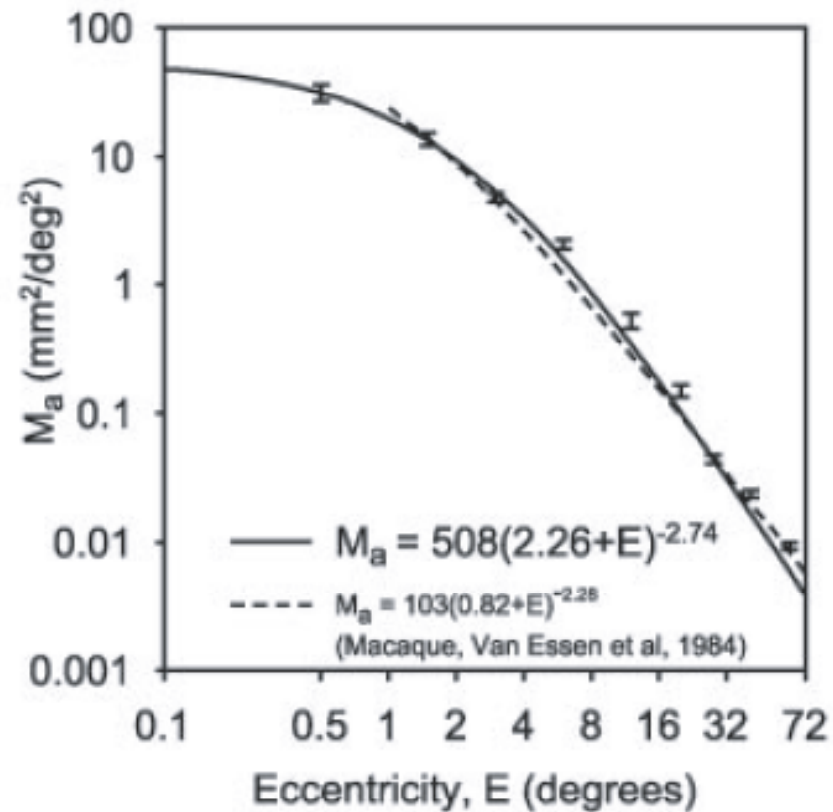

Various numbers

- In the human eye we have a very high density of cones (the color sensitive photoreceptors) in the central part of the retina and a decreasing density when we move towards the periphery. The second kind of receptors (the rods, sensitive to luminance), are absent in fovea, but they have a similar spatial distribution.
- In fact the cone density in the *foveola* (the central part of the fovea) is estimated at about **150–180,000 cones/mm²**. Towards the retinal periphery, cone density decreases from **6000 cones/mm²** at a distance of **1.5 mm** from the fovea to **2500 cells/mm²** close to the *ora serrata* (the *extremity* of the optic part of the retina, marking the limits of the percipient portion of the membrane).
- Rod density peaks at **150,000 rods/mm²** at a distance of about **3–5 mm** from the foveola.
- Cone diameter increases from the center (**3.3 μm** at a distance of **40 μm** from the foveola) towards the periphery (about **10 μm**). Rod diameter increases from **3 μm** at the area with the highest rod density to **5.5 μm** in the periphery.

Logpolar mapping

$$w = f(z) = \log_a(z), \quad w, z \in \mathbb{C}$$

$$z = x + iy = r(\cos \varphi + i \sin \varphi)$$

$$w = \rho(z) + i\vartheta(z)$$

$$z = re^{i\varphi}$$

$$\begin{cases} \rho = \log_a r \\ \vartheta = h\varphi \end{cases}$$

Geometrical interpretation

$$\begin{cases} \eta = q \vartheta \\ \xi = \log_a \frac{\rho}{\rho_0} \end{cases}$$

ρ and ϑ are the standard polar coordinates

$$\begin{cases} x = \rho \cos \vartheta \\ y = \rho \sin \vartheta \end{cases}$$

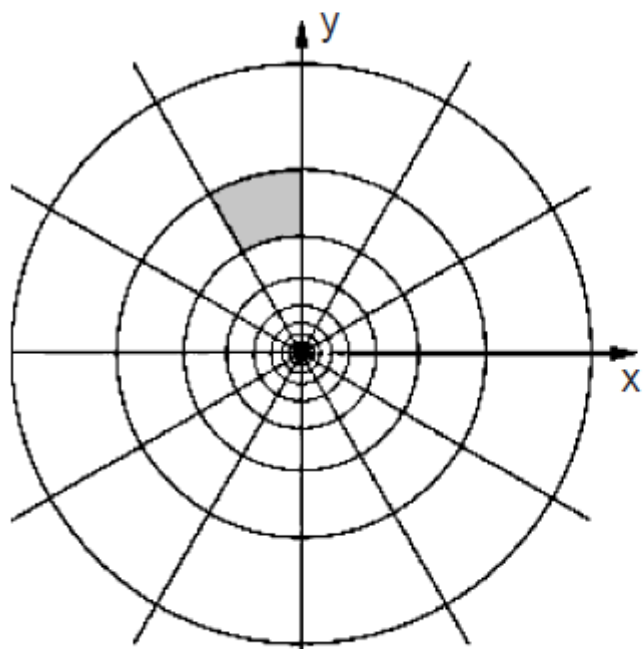

(a)

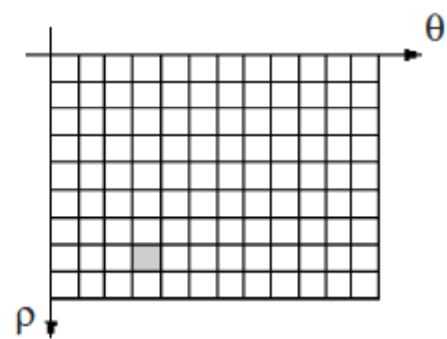

(b)

Log-polar images

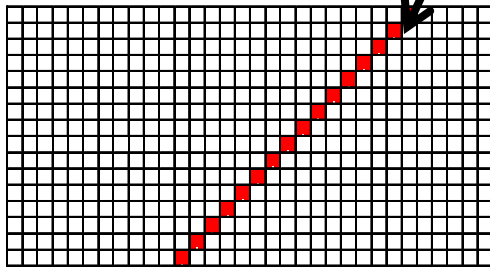
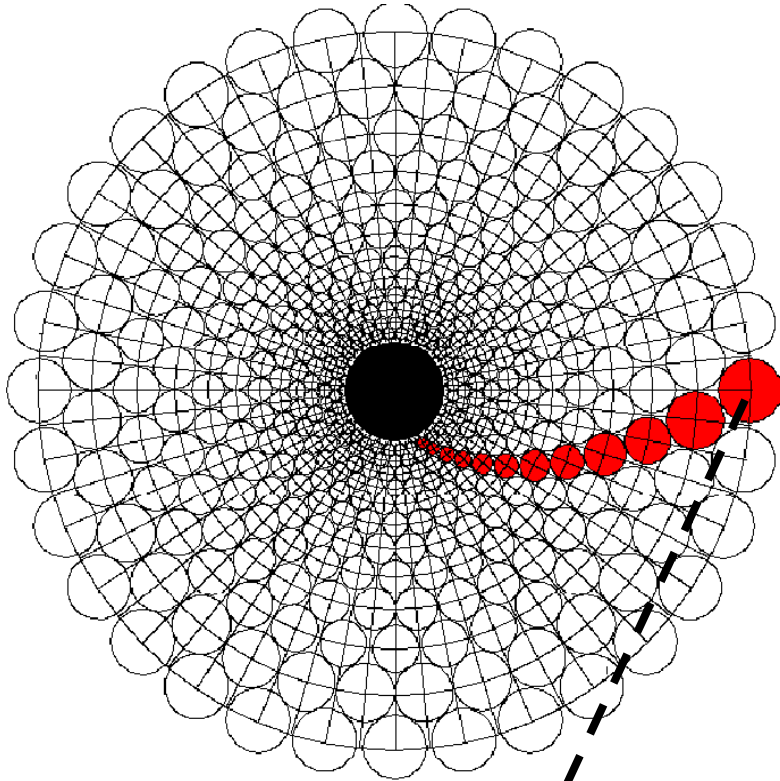

Properties

- Conformal mapping, proximity
 - Use of local operators
- Scale change
 - Translation along the real axis
- Rotation change
 - Translation along the imaginary axis
- Translations
- Fourier-Mellin Transform

Angle preservation

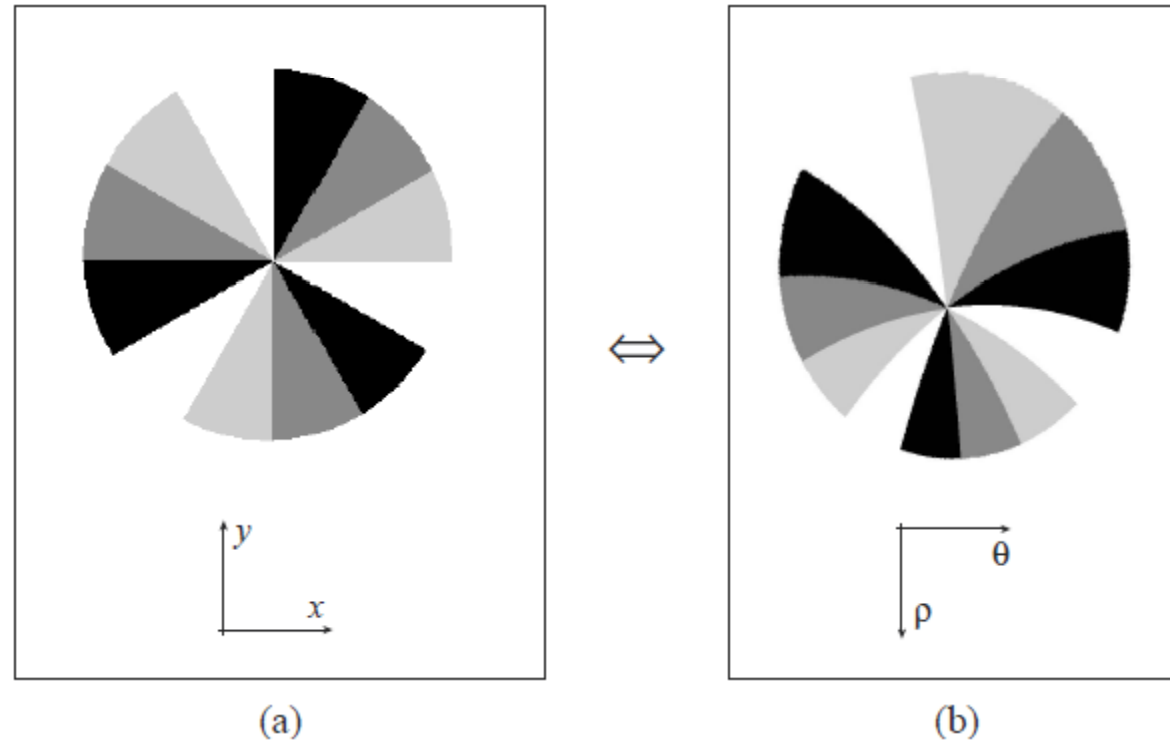

Figure 4.1. Angle Preservation: The angles are locally preserved after a log-polar Transformation. (a) Cartesian domain. (b) log-polar domain. Please note that both images a and b are particulars, so the origin of the mapping falls outside of the cartesian image.

Scale

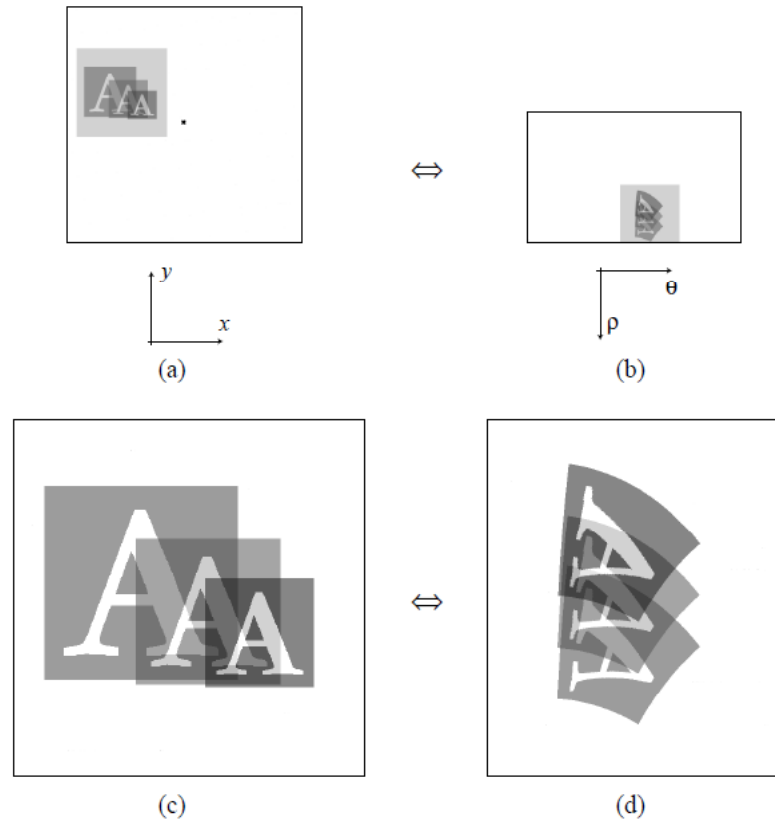

Figure 4.2. Scale Change: A pure scale change referred to the origin of the mapping, with no translational components, becomes a pure translation after the log-polar transform. (a) Cartesian domain. (b) log-polar domain. (c), (d) Enlargement of the shaded areas respectively in (a) and (b).

Rotation invariance

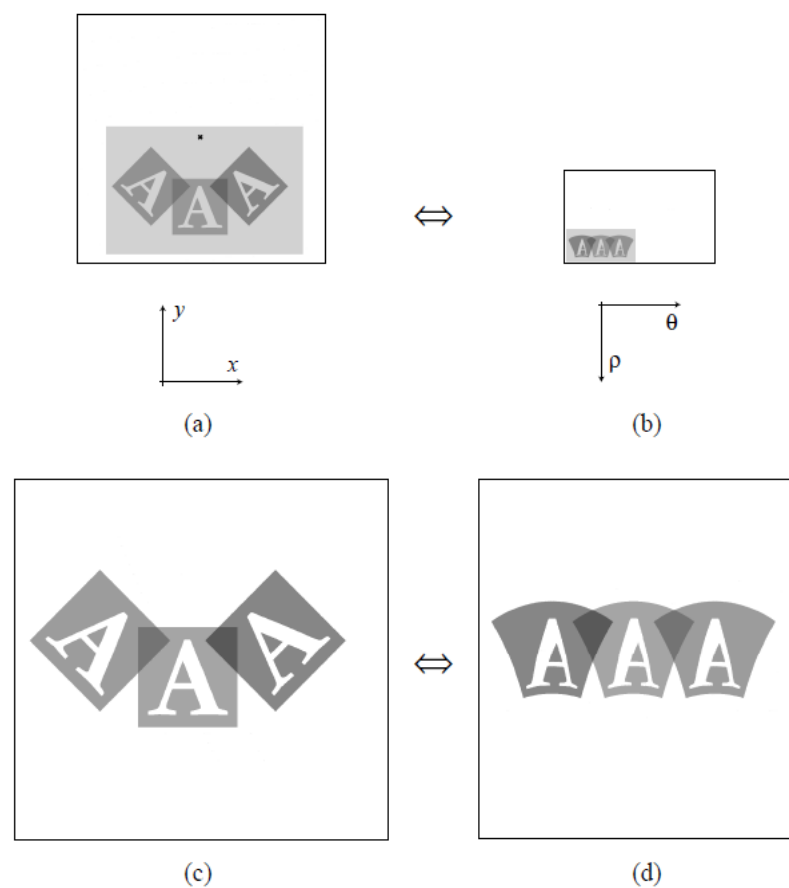

Figure 4.3. Rotation: A pure rotation referred to the origin of the mapping, with no translational components, becomes a pure translation after the log-polar transform. (a) Cartesian domain. (b) log-polar domain. (c), (d) Enlargement of the shaded areas respectively in (a) and (b).

Examples of rot-scale invariance



Translations

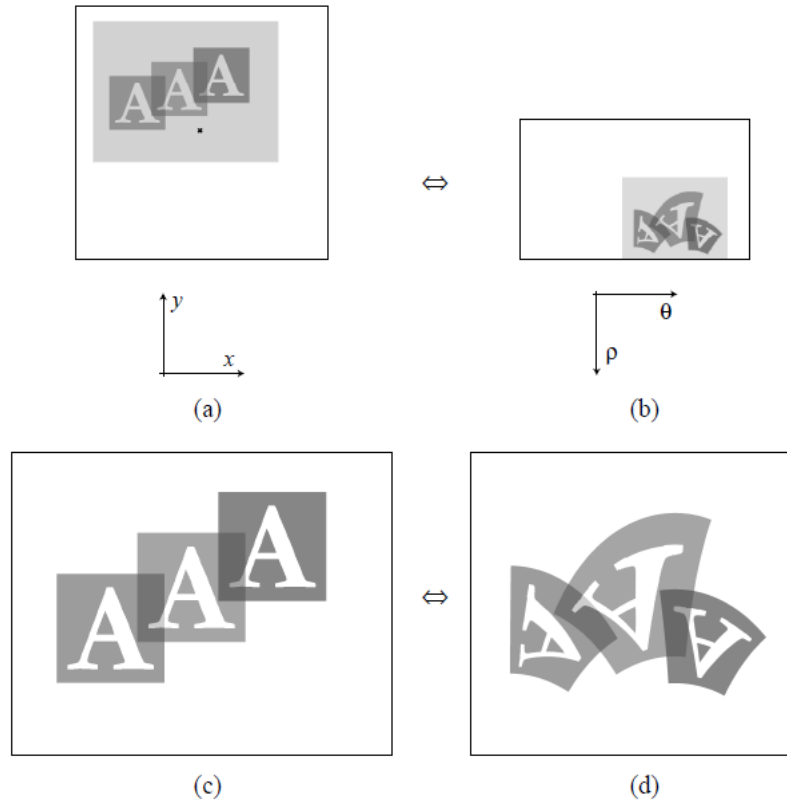

Figure 4.4. Translation: A pure translation implies a deformation of the object after the log-polar transform. (a) Cartesian domain. (b) log-polar domain. (c), (d) Enlargement of the shaded areas respectively in (a) and (b).

Fourier-Mellin

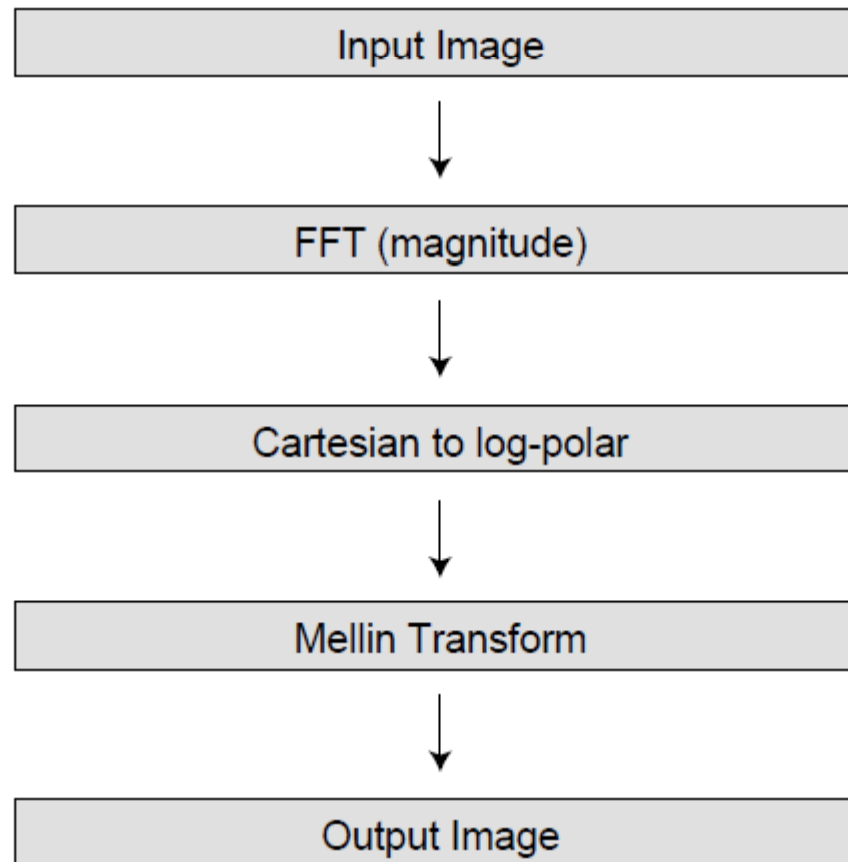
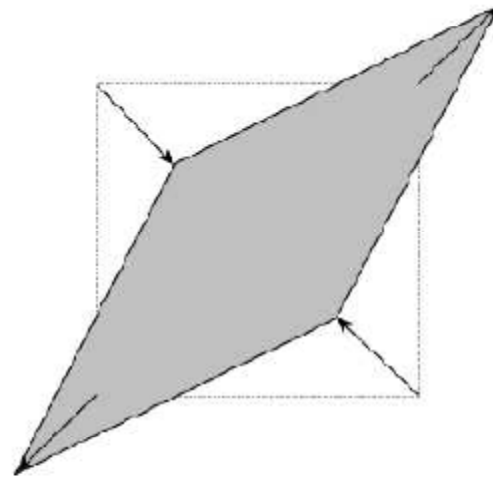
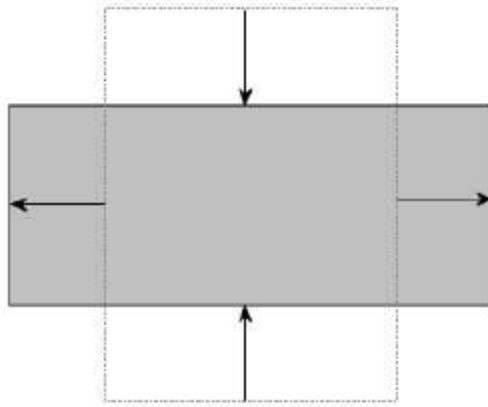
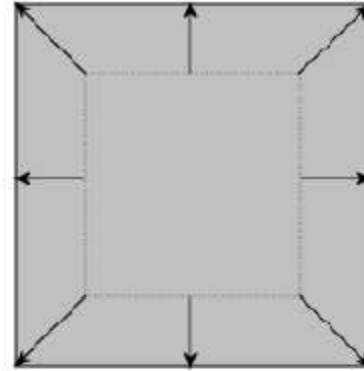
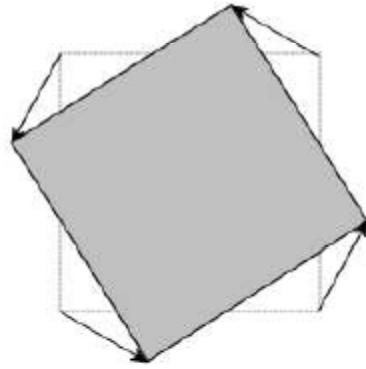
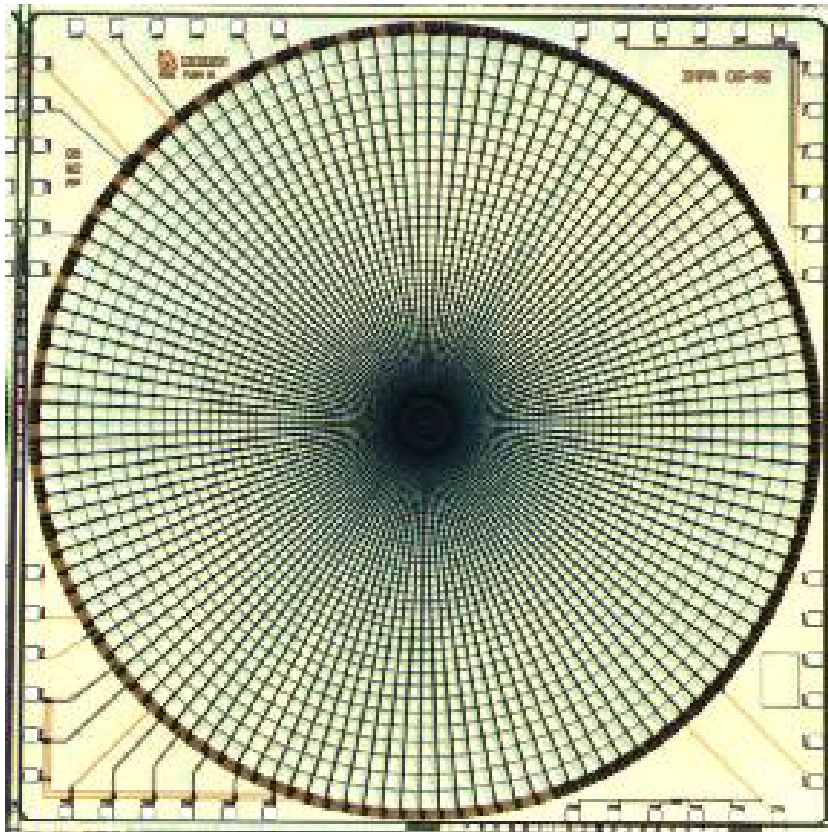

Figure 4.5. The Fourier-Mellin Transform.

Logpolar optical flow



1996 – CMOS



Monochromatic
8000 Pixel (128x56)
Diameter 8.1 mm
Min Pix Size = 14 μm
Max/Min = 14.
Q = 600

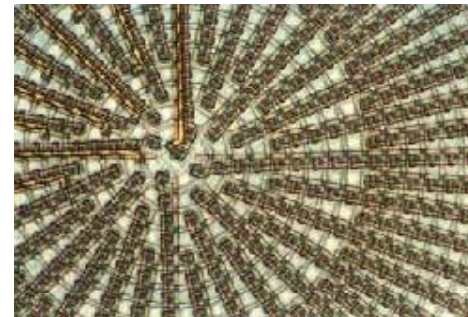

“polar” fovea

1998 – CMOS Color

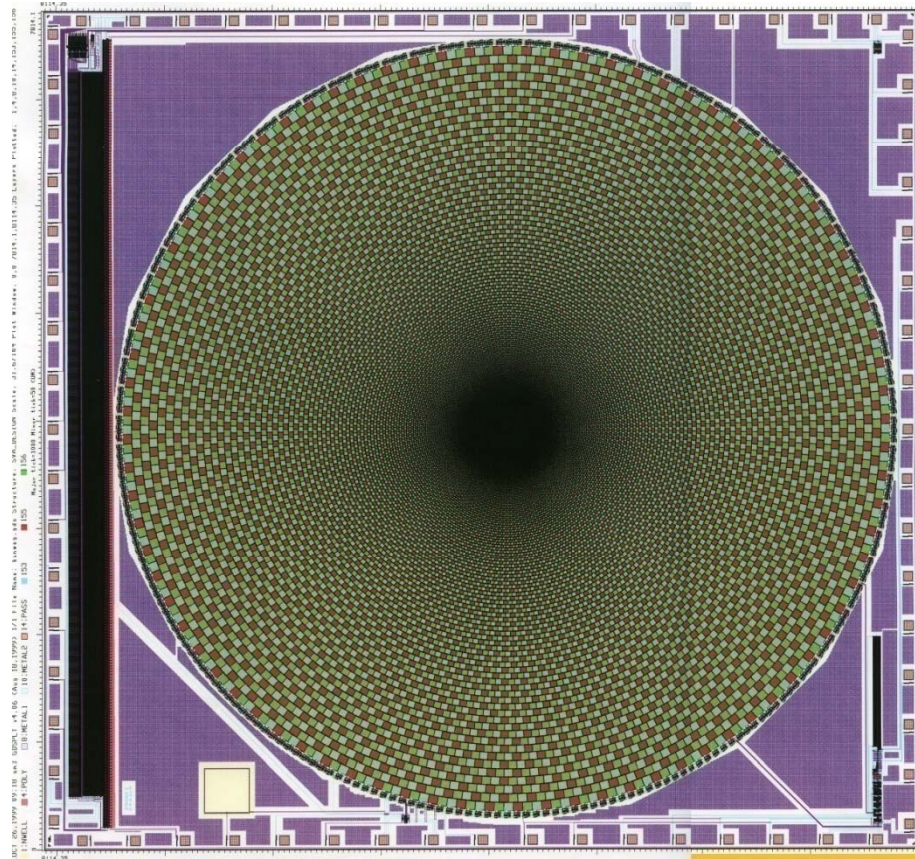

Same Layout

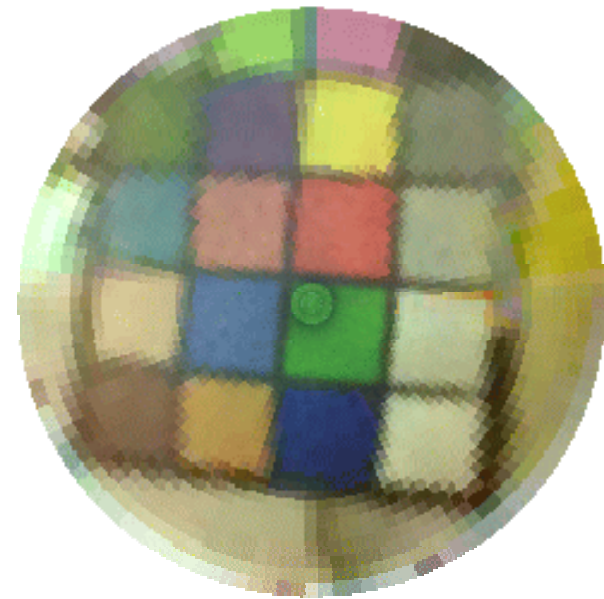

How to compare Giotto-2 with a constant resolution sensor array?

Suppose we start with 5000 pixels at constant resolution

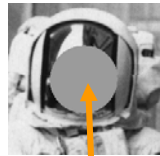

27000 pixels



5000 pixels



The same 5000 pixels plus 27000 retina-like pixels

**33,000 pixels with same field of view
(less resolution)**



Enlarging the constant resolution image shows the loss in resolution



The two images are shown so that the size of the smallest pixel is the same (same maximum resolution)

Another example



...advantages increase

Table 1. A comparison between three generations of log-polar sensors.

Sensor Version	Total Number of Pixels	Pixels in Fovea	Pixels in Periphery	Total Number of Rings	Pixels per Ring
CCD	2022	102	1920	30	64
CMOS 8k	8013	845	7168	76	128
CMOS 33k	33193	5473	27720	152	252

Sensor Version	Rings in Fovea	Rings in Periphery	Pixels in Periphery	Angular Amplitude	Logarithm Base
CCD	—	30	1920	5.413°	1.094
CMOS 8k	20	56	7168	2.812°	1.049
CMOS 33k	42	110	27720	1.428°	1.02337

Sensor Version	Ø of the Sensor	Size of the Smallest Pixel	R	Q	Technology Used	Radius of the Fovea
CCD	9400 μm	30 μm	13.7	300	1.5 μm	317 μm
CMOS 8k	8100 μm	14 μm	14	600	0.7 μm	285 μm
CMOS 33k	7100 μm	6.5 μm	17	1100	0.35 μm	273 μm

Application

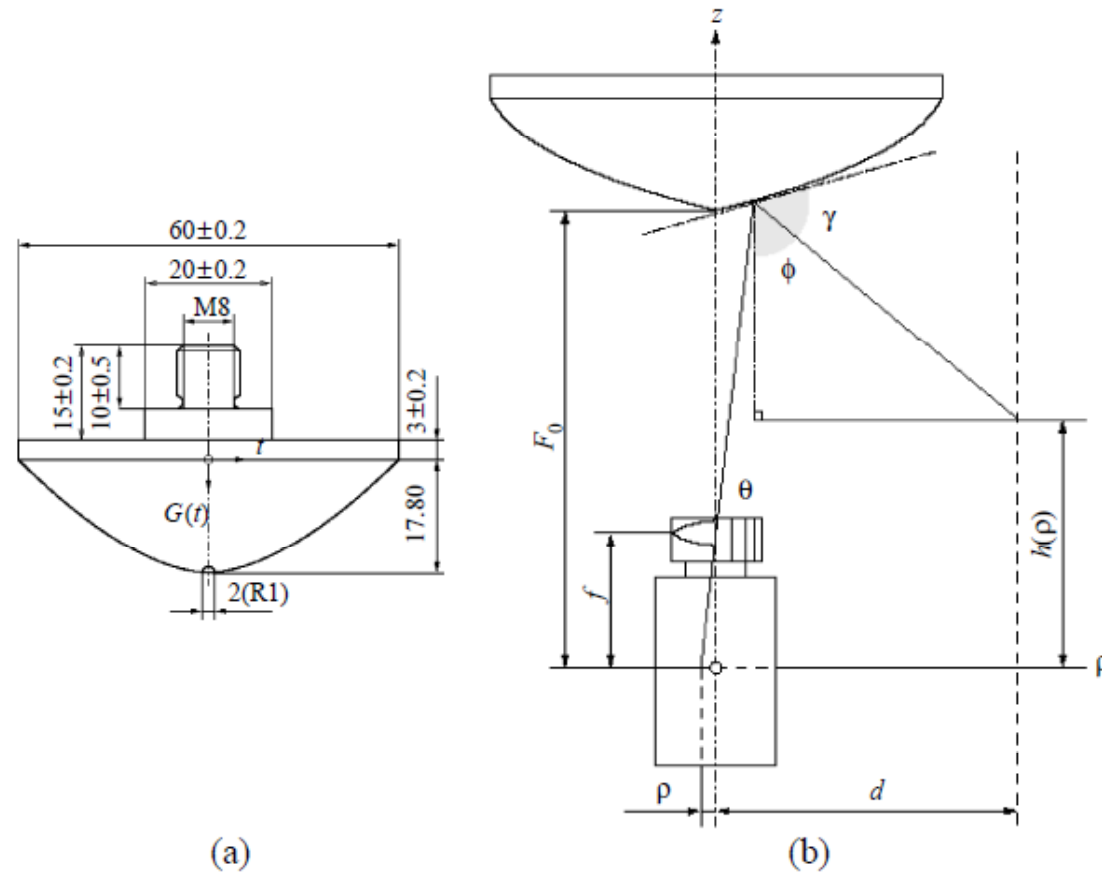

Figure 5.2. Mirror design: (a) Profile of the mirror. (b) The mirror is designed so that vertical resolution of a cylindrical surface is mapped into constant radial resolution in the image plane.



(a)



(b)

Figure 5.1. Panoramic View: (a) Image acquired by an OMNIVIEWS log-polar camera (software simulation). (b) Image acquired by a conventional omnidirectional camera. Note that the image from OMNIVIEWS camera is immediately understandable while the image from a conventional camera requires more that 1.5 million operations to be transformed into something similar with no added advantage.